



Bureau of Energy Efficiency



सत्यमेव जयते
Government of India
Ministry of Power



german
cooperation
DEUTSCHE ZUSAMMENARBEIT

giz Deutsche Gesellschaft
für Internationale
Zusammenarbeit (GIZ) GmbH

ANGAN

Augmenting Nature by Green Affordable New-habitat

A Courtyard for Revolutionary Change in Building Energy Efficiency

An International Conference on Building Energy Efficiency

9th-11th September, 2019 | Hotel The LaLiT, New Delhi





Bureau of Energy Efficiency



सत्यमेव जयते
Government of India
Ministry of Power



giz Deutsche Gesellschaft
für Internationale
Zusammenarbeit (GIZ) GmbH

THIS PRESENTATION WAS SHARED BY

R S Agarwal

IIT Delhi

FOR THE SESSION:

“State-of-the-art Cooling Systems, including District Cooling System”

DURING ANGAN 2019

Knowledge Partner

teri | THE ENERGY AND
RESOURCES INSTITUTE
Creating Innovative Solutions for a Sustainable Future

Event Partner

TEC INDIA TM
EVENT & BRAND MANAGEMENT CO.

**State-of-the-art
Cooling Systems**

**State-of-the art Cooling
Systems, including District
Cooling Systems**

Radhey S. Agarwal
Technical Advisor (AC&R and Montreal Protocol)

Low Penetration of Cooling: Relative Energy Consumption for cooling in India

4

- ❑ Very low penetration of per capita energy consumption for cooling in India
- ❑ Cooling demand is expected to grow at fast rate

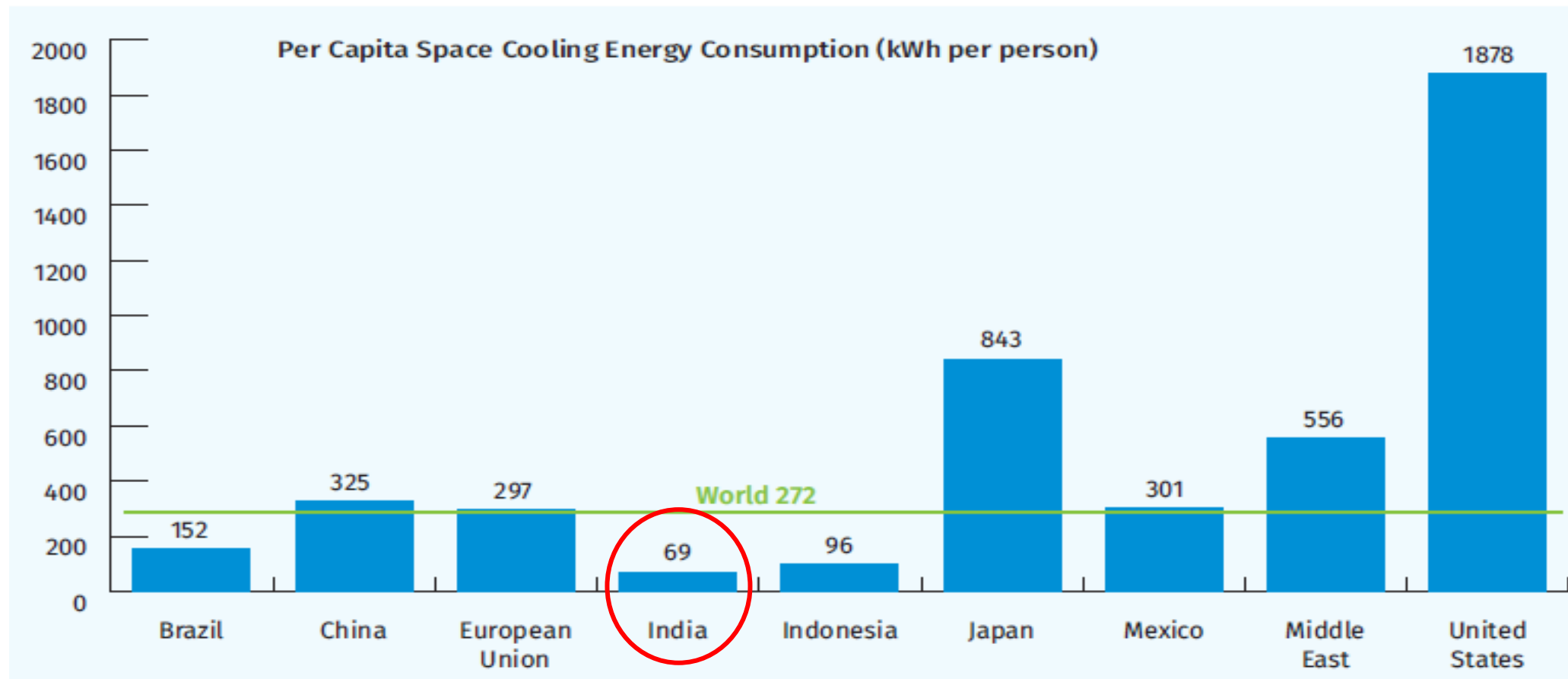

*Image Source: India Cooling Action Plan 2019

Market growth: Sector-wise Growth in Cooling Demand

5

Note: Cooling demand is increasing globally: 8% in A5 and 2% in non-A5 countries

- ❑ The aggregated nationwide cooling demand, in Tonnes of Refrigeration (TR), is projected to grow around 8 times by 2037-38 as compared to the 2017-18 baseline.
- ❑ The building sector cooling demand shows the most significant growth at nearly 11 times as compared to the baseline.

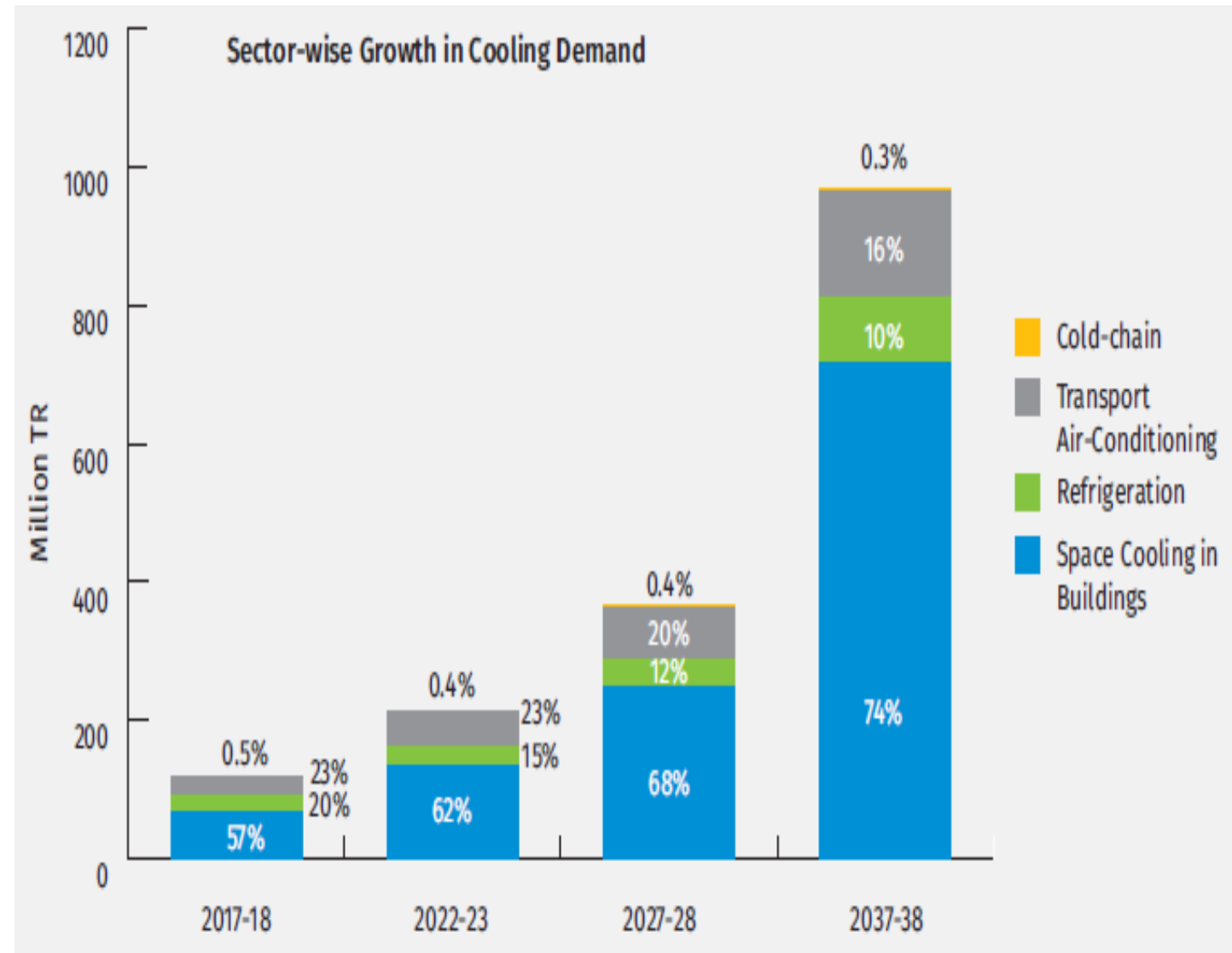

Overview of Technology Options

6

Vapour Compression

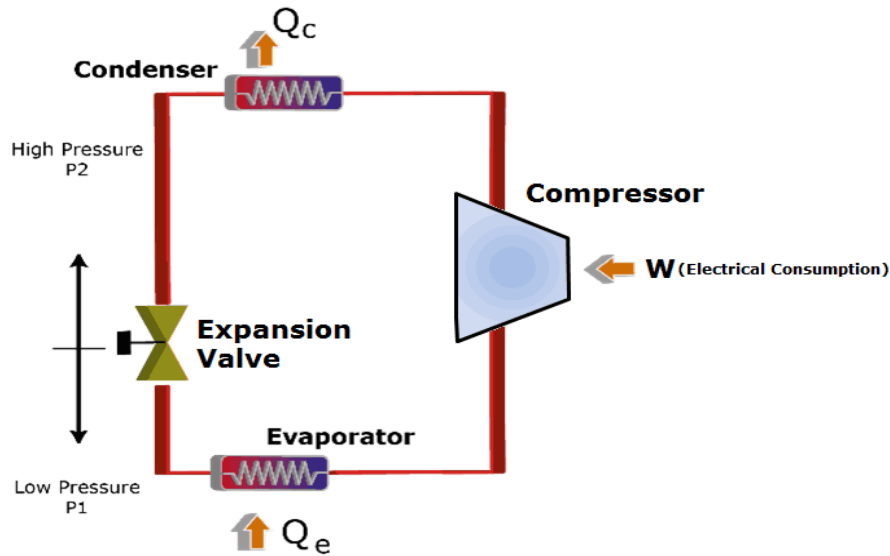

Thermo-electric

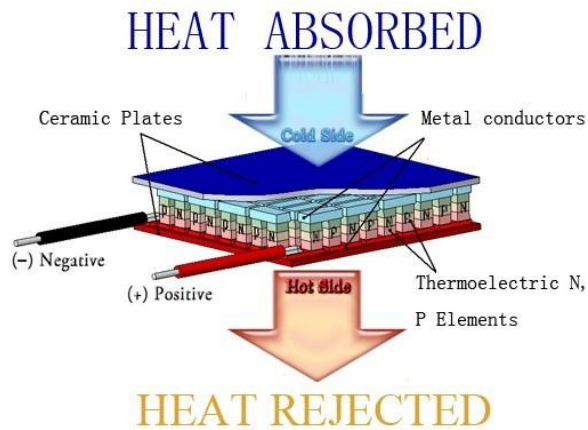

Vapour Absorption

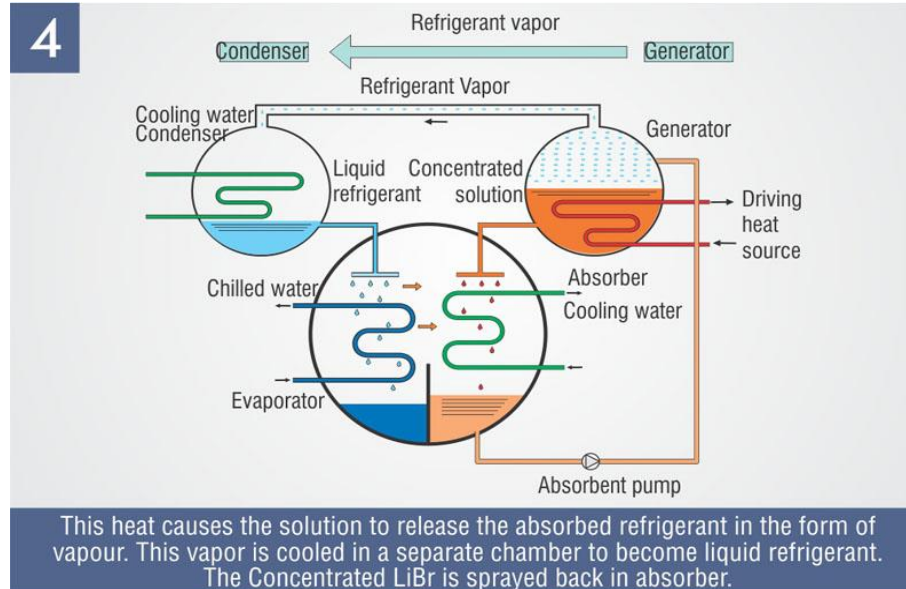

Magnetic Cooling

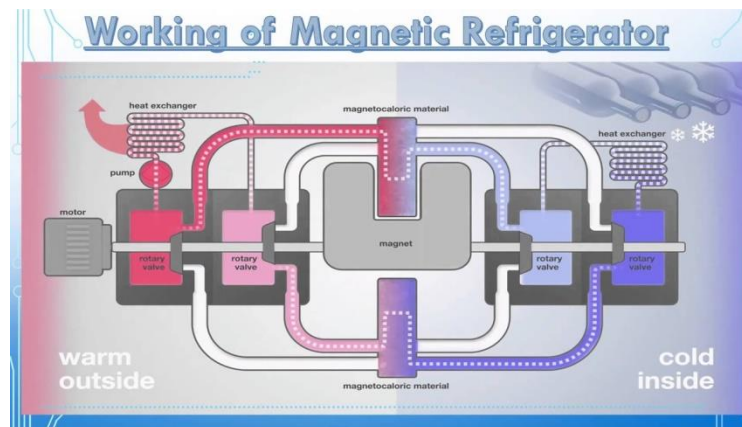

Ejector System

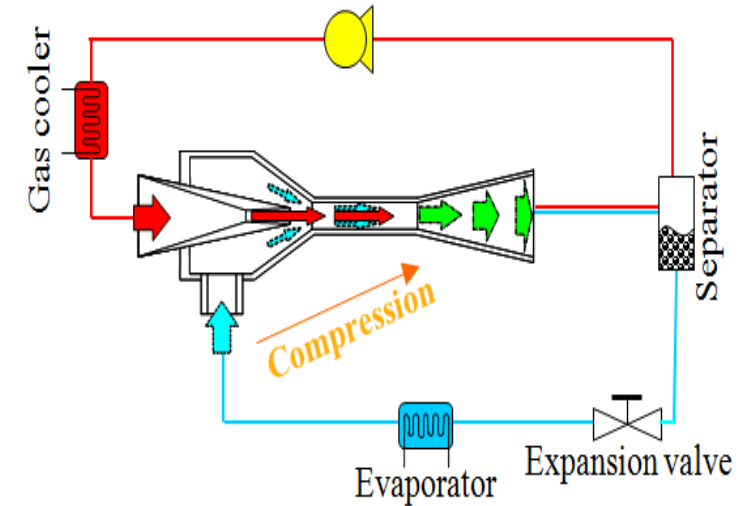

Evaporative Cooling

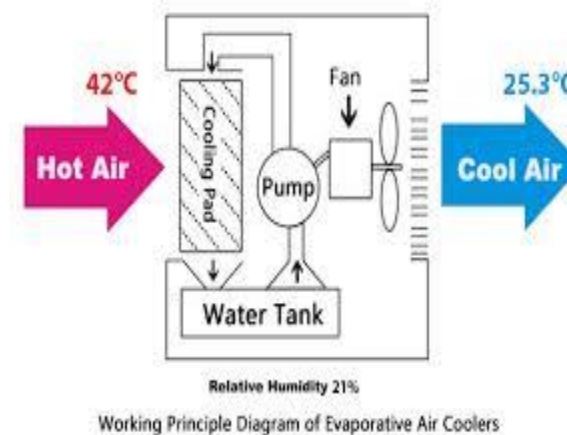

Fans



Vapor Compression Technology :

- Widely used technology

Not-in Kind Technologies

- Vapor absorption technology;
- District cooling with low-GWP refrigerants- Vapour compression. Vapour absorption;
- Try-generation: power, cooling & heating;
- Evaporative Cooling
- Evaporative cooling with desiccant

Solar thermal

- Space heating (and cooling?)
- Desiccant regeneration

Industrial process heat recovery;

Why Vapour Compression Systems widely used?

8

❑ Compression Systems:

- Very effective & Reliable,
- Energy efficient and cost competitive;
- Continued Research & Development to improve in terms of application, performance, efficiency, aesthetics, etc.;

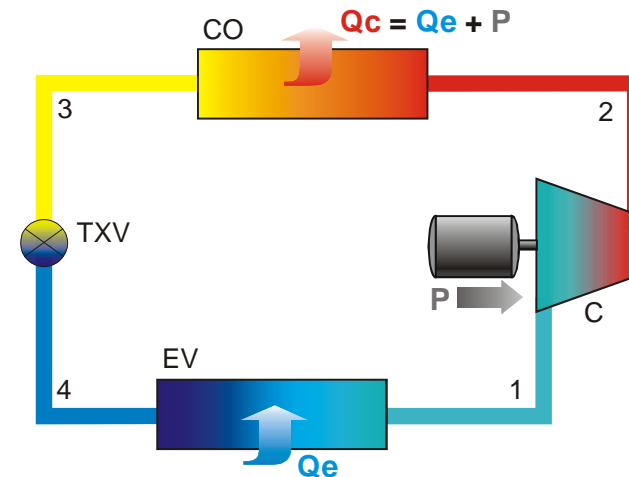

1. Compressor :
AC Motor driven
2. Condenser Fan:
AC Motor Driven
3. Expansion Device:
Capillary
4. Evaporator Blower :
AC Motor Driven

- High Pressure side gas
- High Pressure side liquid
- Low Pressure side liquid
- Low Pressure side gas

Note: More than 85% of the global cooling requirements are met through compression systems;

Improved VC System Efficiency?

(Source: Piotr Domeski, NIST)

9

○ Advanced cycles

- Internal heat exchangers
- Economizer cycle

○ Advanced optimization; component level and system level

- Compressor
- Heat exchangers (heat transfer surfaces, refrigerant circuitry optimization)

○ Efficient electric motors (ECM vs permanent split-capacitor)

○ Fault detection and diagnostics

○ Quality commissioning

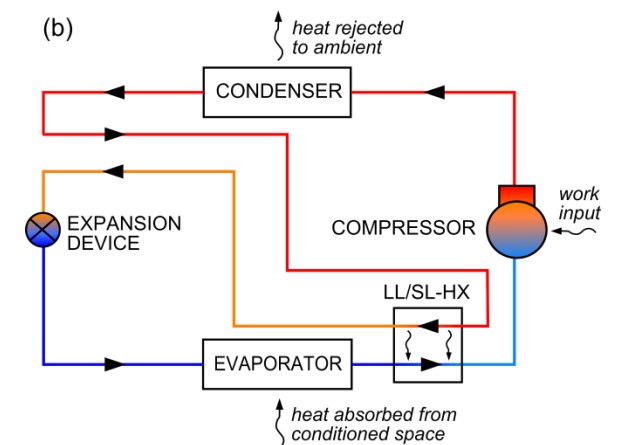
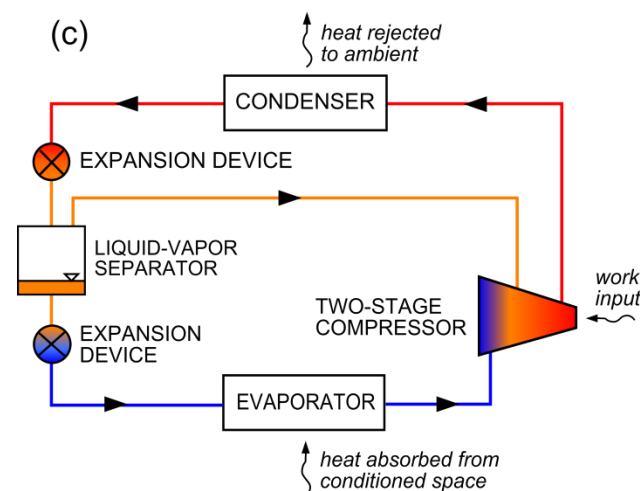
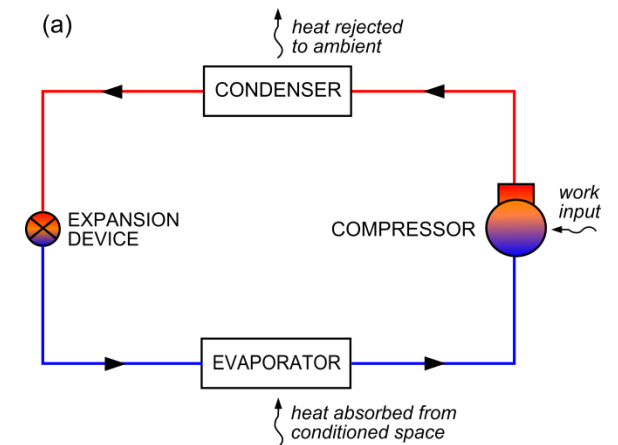

Components Responsible for Energy Efficiency

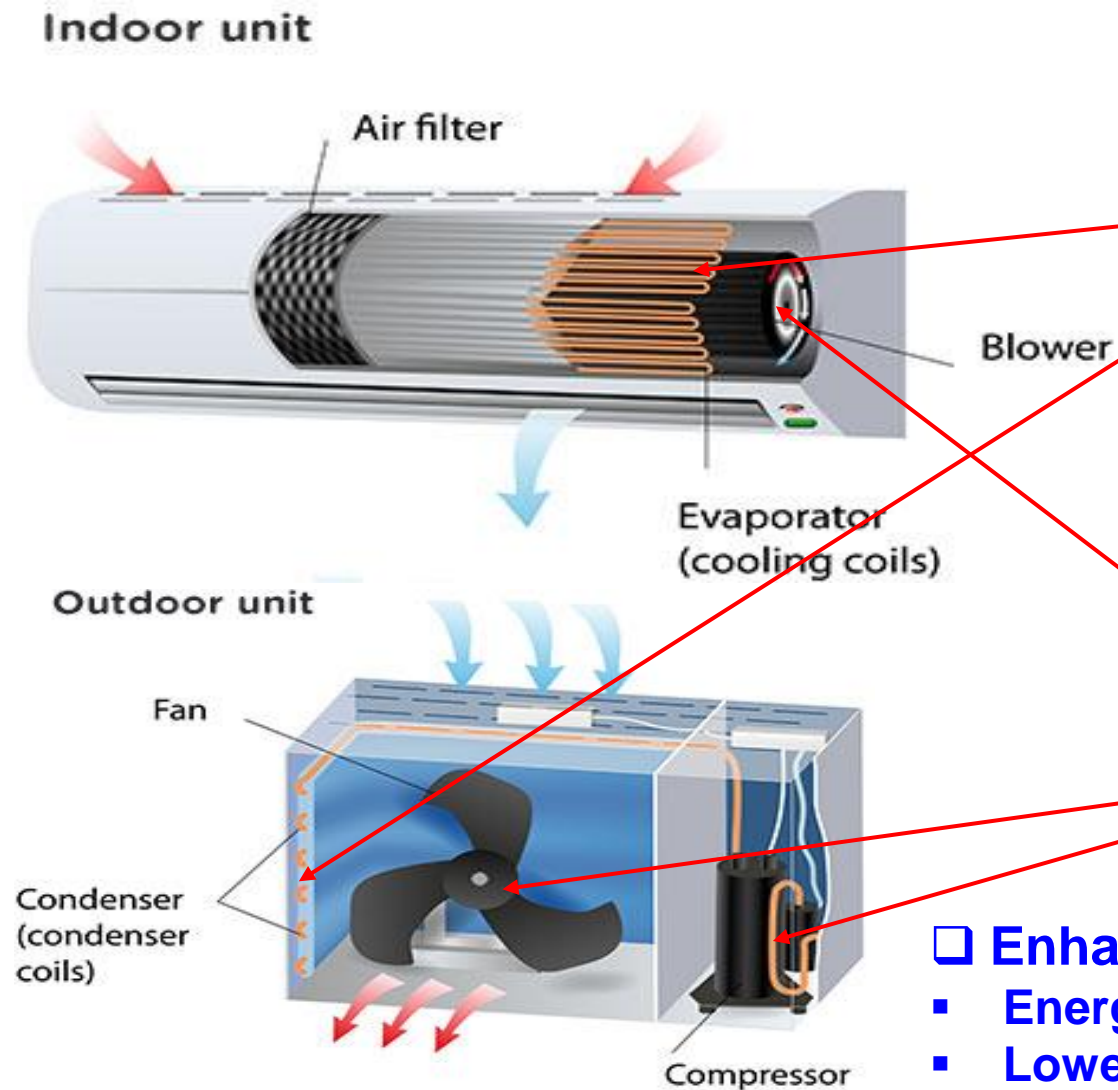

**Heat Exchangers:
Chang in Technology, Design & Size**

**Power consuming Parts:
Major Technology Change**

❑ Enhancement of Energy Efficiency by:

- Energy efficient motors including DC motors
- Lower tube diameter/ microchannel Heat Exchangers
- Electronic expansion valve
- Inverter Technology

State-of-the-Art Technologies: Variable Speed Technologies

11

Inverter ACs



Fixed Speed ACs

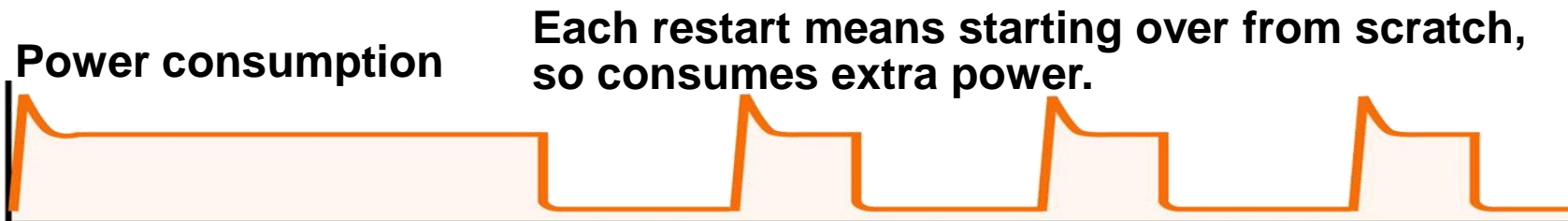

25% Saving

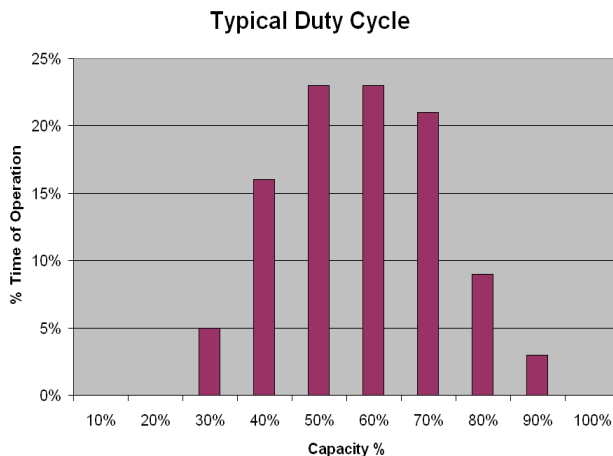

18% Saving

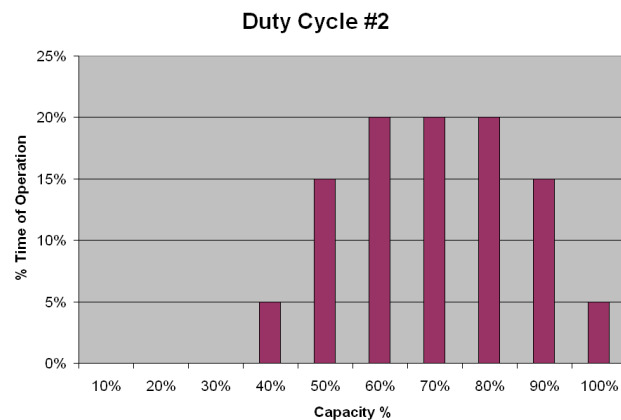

11% Saving

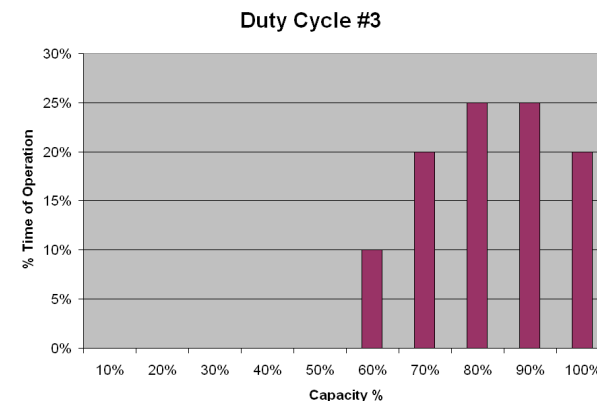

Compressor Duty Cycle:

- ACs are installed based on maximum load;
- ACs operate most of the time at part-load;
- Inverter ACs provide cooling as per load;
- Resulting in significant energy savings;
- Energy Savings depend on duty cycle.

District Cooling: Vapour Compression and/or Vapour Absorption System Integration

12

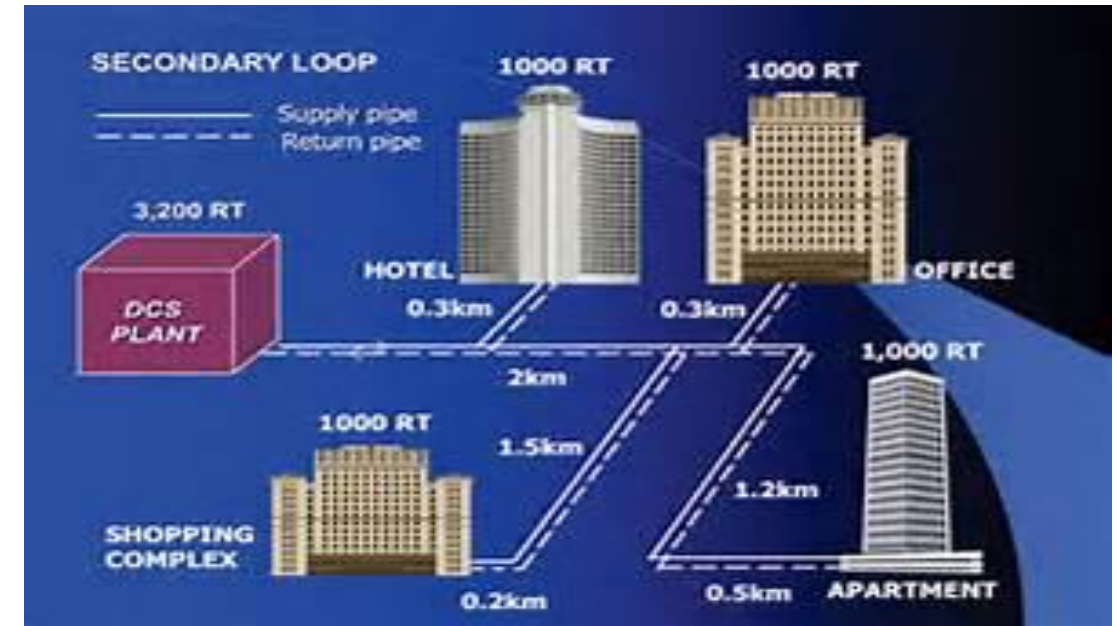

- ❑ The DC system is best suited to areas that have appreciable concentration of cooling loads.
- ❑ **Higher capital investment**
- ❑ **Utilization Factor to be properly Assessed**
- ❑ The DC systems are good for the following:
 - ❑ Densely populated urban areas, mixed uses of buildings
 - ❑ High-density building clusters with high cooling requirement
 - ❑ Tall building complexes
 - ❑ Industrial complexes

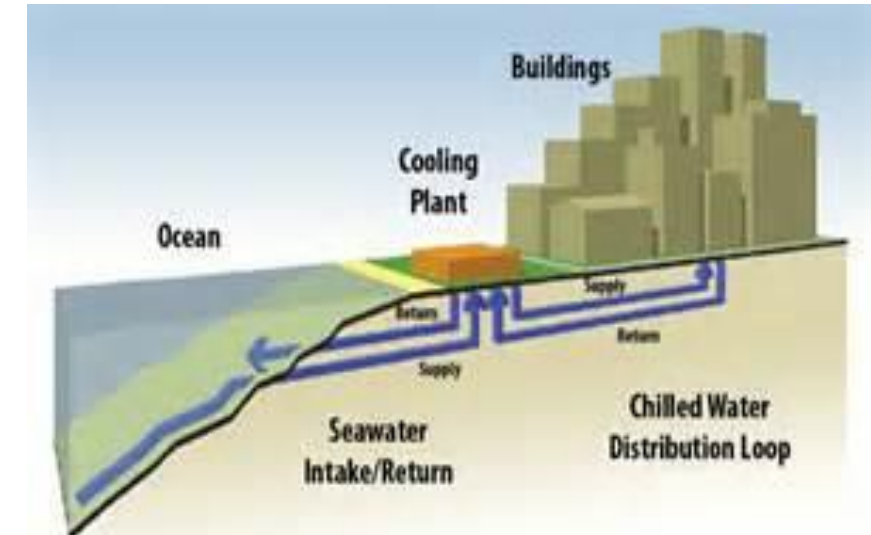

Power Generation Vapour Absorption System Integration-Tri-generation system

13

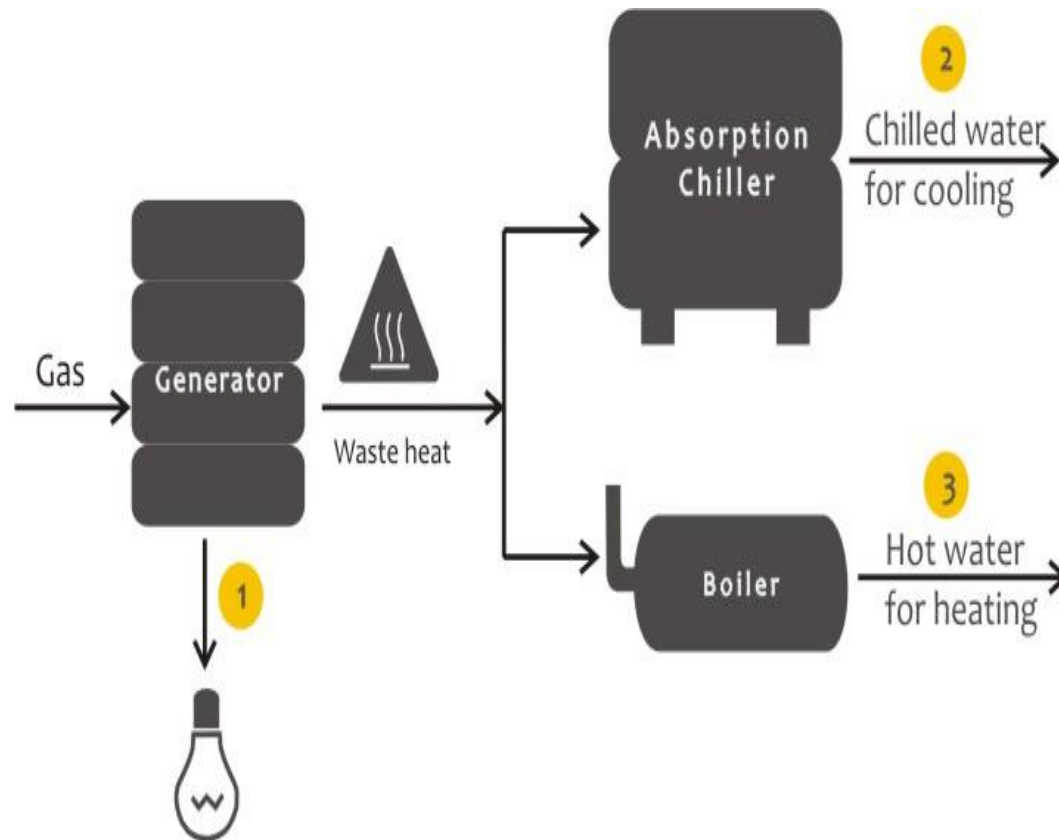

**Tri-generation system of 347 kW (Power)
+ 1250 kW (A/C) + 20 kW (Heating)**

- ❑ Provides Power. Cooling & Heating/hot water
- ❑ Power generation is at sub-optimal efficiency: Lower utilization of Availability of Fuel
- ❑ Excellent system where gas fuel/waste heat available and power, cooling and heating are required

Evaporator Cooling: Direct & Indirect

14



Indirect Direct Evaporative Cooling System:

- ❑ **Evaporative Cooling Offers a huge potential in the country especially in hot and dry climatic zones in the country;**
- ❑ **Indirect-direct evaporative coolers (IDEC) offer the advantages of both direct evaporative coolers and indirect evaporative coolers and cool the process air without adding humidity to the supply air stream.**
- ❑ **The Indirect & Direct Cooling can be used in all climatic zones, humid climates should be supplemented with additional air draft to realize thermal comfort.**

Integrated Approach for Efficient & Sustainable Cooling

15

An integrated approach encompassing cooling load reduction and change in use pattern along with energy efficiency are necessary for sustainable cooling.

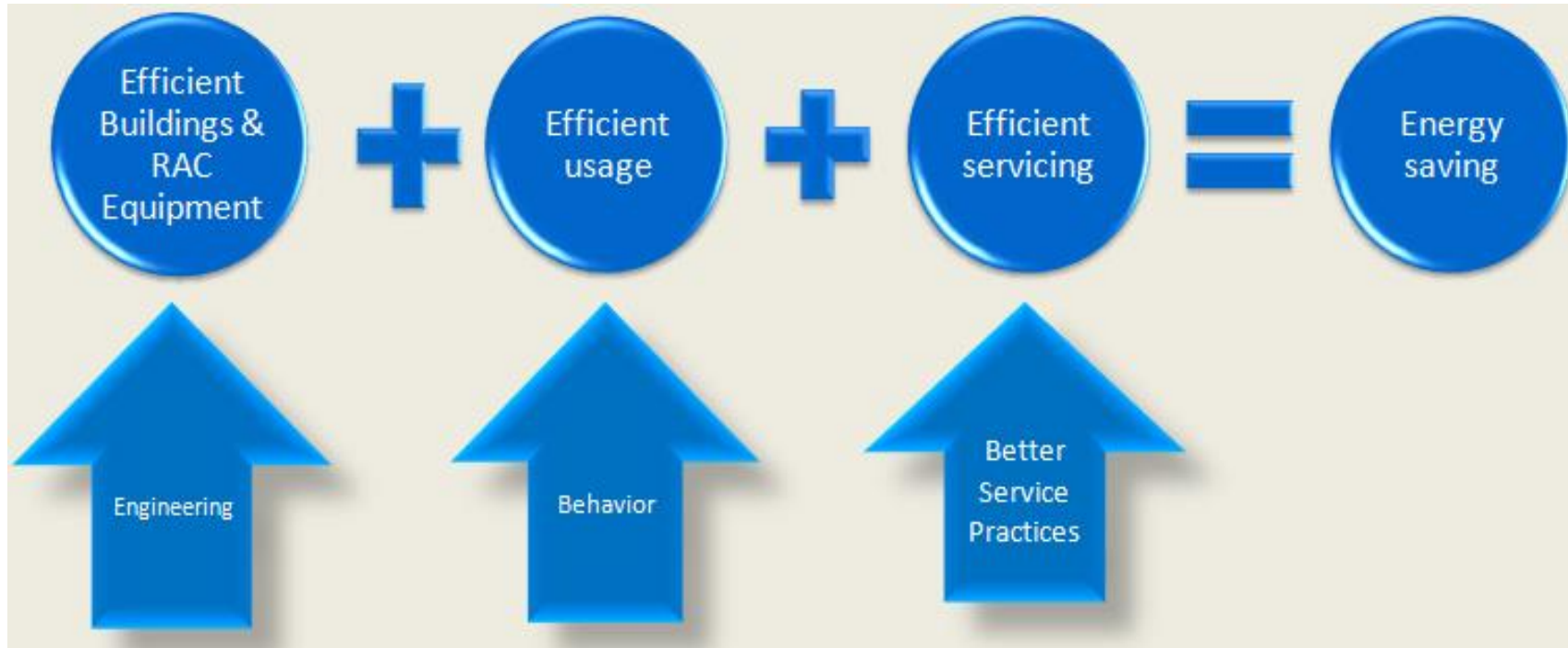

Use Pattern: Minimum Indoor Temperature Setting

16

- Lack of awareness about the importance of preventive maintenance
- Maintain room AC set point at 25 ± 1 Degree C, save money for the same comfort

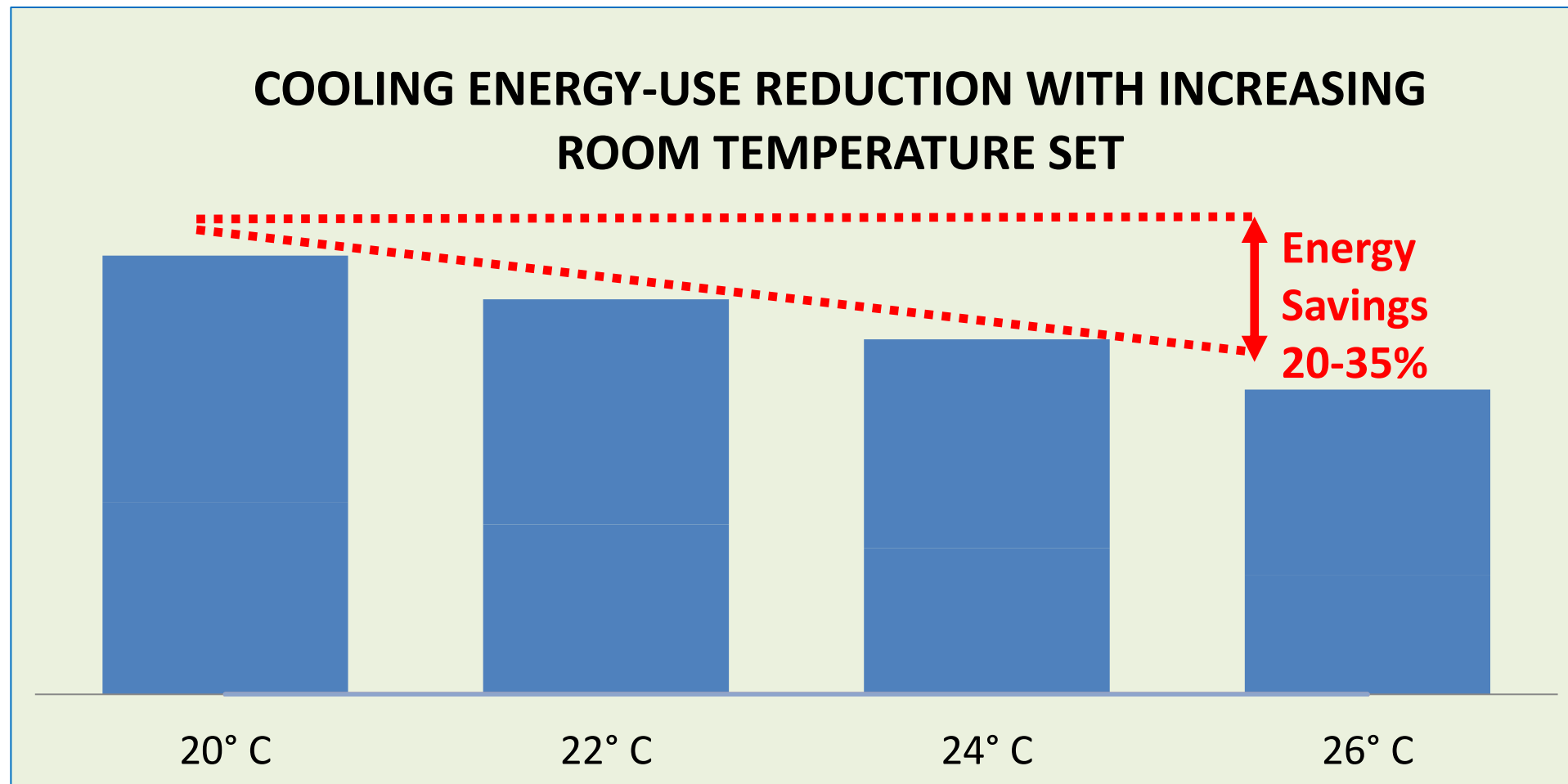

THANK YOU

Prof. Radhey S. Agarwal
Technical Advisor , Ozone Cell, India
E-mail: agarwalrsa@gmail.com